

AVC 016 ... 040 PA/X
DVC 016 ... 040 PX

Angle & Inline valve, pneumatically operated, bellows sealed, with position indicator

Operating Instructions



蒙天真空
M T V A C U U M

Product Identification

In all communications with Pfeiffer Vacuum, please specify the information on the product nameplate. For convenient reference copy that information into the space provided below:

Angle Valve
Aluminum housing

Angle Valve
Stainless steel housing

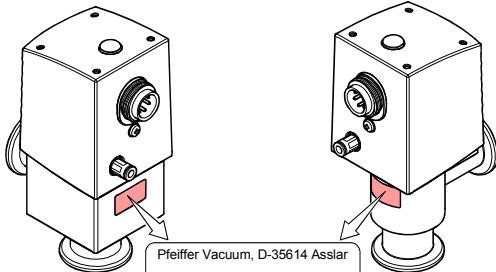

Pfeiffer Vacuum, D-35614 Asstar

Typ:

No:

F-No:



Nominal voltage
(pilot valve)

Inline Valve
Stainless steel housing

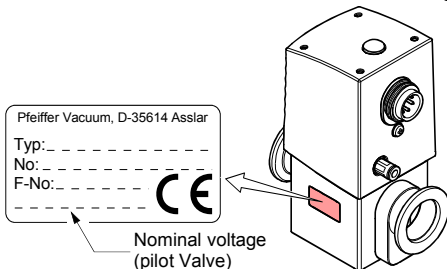

Pfeiffer Vacuum, D-35614 Asstar

Typ:

No:

F-No:



Nominal voltage
(pilot Valve)



Validity

This document applies to products with the following part numbers:



Angle valves ...

... with pilot valve, normally closed (n.c.)

- Aluminum housing

DN 16 ISO-KF	DN 25 ISO-KF	DN 40 ISO-KF	Nominal voltage or voltage range (pilot valve)
PF A38 103	PF A48 103	PF A58 103	24 VAC
PF A38 204	PF A48 204	PF A58 204	24 VDC
PF A38 403	PF A48 403	PF A58 403	100 ... 115 VAC
PF A38 503	PF A48 503	PF A58 503	200 ... 230 VAC

- Stainless steel housing

DN 16 ISO-KF	DN 25 ISO-KF	DN 40 ISO-KF	Nominal voltage or voltage range (pilot valve)
PF A38 133	PF A48 133	PF A58 133	24 VAC
PF A38 234	PF A48 234	PF A58 234	24 VDC
PF A38 433	PF A48 433	PF A58 433	100 ... 115 VAC
PF A38 533	PF A48 533	PF A58 533	200 ... 230 VAC

... with pilot valve, normally open (n.o.)

- Aluminum housing

DN 16 ISO-KF	DN 25 ISO-KF	DN 40 ISO-KF	Nominal voltage (pilot valve)
PF A38 205	PF A48 205	PF A58 205	24 VDC

- Stainless steel housing

DN 16 ISO-KF	DN 25 ISO-KF	DN 40 ISO-KF	Nominal voltage (pilot valve)
PF A38 235	PF A48 235	PF A58 235	24 VDC



... without pilot valve

- Aluminum housing

DN 16 ISO-KF	DN 25 ISO-KF	DN 40 ISO-KF
PF A36 003	PF A46 003	PF A56 003

- Stainless steel housing

DN 16 ISO-KF	DN 25 ISO-KF	DN 40 ISO-KF
PF A36 033	PF A46 033	PF A56 033



Inline Valve ...

... with pilot valve, normally closed (n.c.)

- Stainless steel housing

DN 16 ISO-KF	DN 25 ISO-KF	DN 40 ISO-KF	Nominal voltage or voltage range (pilot valve)
PF D38 133	PF D48 133	PF D58 133	24 VAC
PF D38 234	PF D48 234	PF D58 234	24 VDC
PF D38 433	PF D48 433	PF D58 433	100 ... 115 VAC
PF D38 533	PF D48 533	PF D58 533	200 ... 230 VAC

... with pilot valve, normally open (n.o.)

- Stainless steel housing

DN 16 ISO-KF	DN 25 ISO-KF	DN 40 ISO-KF	Nominal voltage (pilot valve)
PF D38 235	PF D48 235	PF D58 235	24 VDC

... without pilot valve

- Stainless steel housing

DN 16 ISO-KF	DN 25 ISO-KF	DN 40 ISO-KF
PF D36 033	PF D46 033	PF D56 033



The part number (No) can be taken from the product nameplate.
If not indicated otherwise in the legends, the illustrations in this document correspond to the valve with part number PF A48 103. They apply to the other valves by analogy.

We reserve the right to make technical changes without prior notice.

All dimensions are indicated in mm.

Intended Use

The valves are used as shut-off and venting devices for vacuum applications.

Scope of Delivery

- 1× Valve
- 1× Female cable connector
- 1× Instant push-in fitting $\varnothing 6$ mm
- 1× Operating Instructions German
- 1× Operating Instructions English
- 1× Safety Guide



Contents

Product Identification	2
Validity	3
Intended Use	5
Scope of Delivery	5
1 Functional Principle	8
1.1 Valve with Pilot Valve, Normally Closed	8
1.2 Valve with Pilot Valve, Normally Open	10
1.3 Valve without Pilot Valve	12
2 Safety	14
2.1 Symbols Used	14
2.2 Personnel Qualifications	14
2.3 General Safety Instructions	15
2.4 Liability and Warranty	15
3 Technical Data	16
4 Installation	21
4.1 Vacuum Connection	21
4.2 Compressed Air Connection	23
4.3 Power Connection	26
5 Operation	31
5.1 Valve with Pilot Valve, Normally Closed	31
5.2 Valve with Pilot Valve, Normally Open	32
5.3 Valve without Pilot Valve	32
6 Deinstallation	33
6.1 Power Connection	33
6.2 Compressed Air Connection	35
6.3 Vacuum Connections	37
7 Maintenance / Repair	39
7.1 Cleaning / Replacing Bellows and Seals	40
7.2 Replacing the Cover	43
8 Spare Parts	45
9 Accessories	46
10 Returning the Product	47



11 Disposal

48

For cross references within this document, the symbol (→  XY) is used.



1 Functional Principle

1.1 Valve with Pilot Valve, Normally Closed

Opening action

When the pilot valve is activated, the angle valve is opened by the pneumatic actuator. The visual position indicator becomes visible and the electrical position indicator "valve open" is activated.

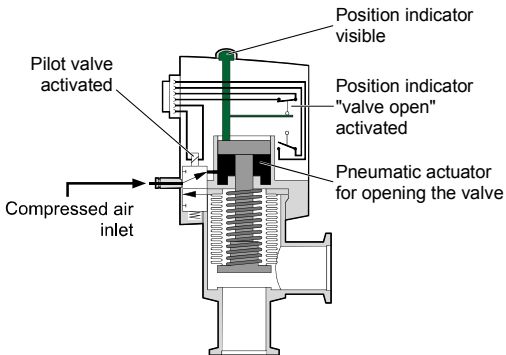

Closing action

When the pilot valve is deactivated, the angle valve is closed by the pressure spring. The visual position indicator is no longer visible and the electrical position indicator "valve closed" is activated.

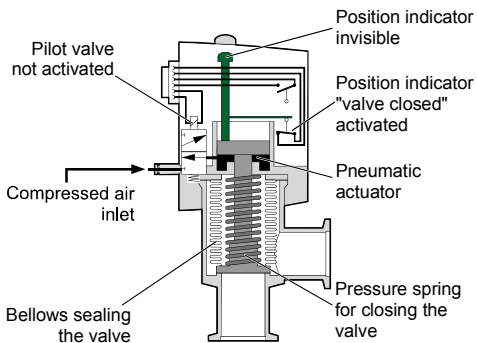

1.2 Valve with Pilot Valve, Normally Open

Opening action

When the pilot valve is deactivated, the angle valve is opened by the pneumatic actuator. The position indicator becomes visible and the electrical position indicator "valve open" is activated.

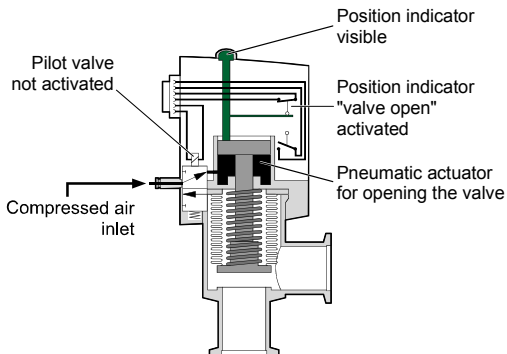

Closing action

When the pilot valve is activated, the angle valve is closed by the pressure spring. The position indicator is invisible and the electrical position indicator "valve closed" is activated.

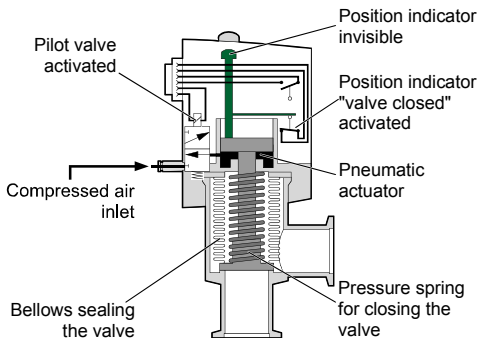

1.3 Valve without Pilot Valve

Opening action

When compressed air is admitted, the angle valve opens. The visual position indicator becomes visible and the electrical position indicator "valve open" is activated.

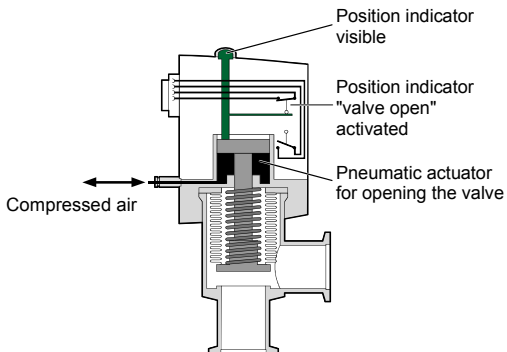

Closing action

When no compressed air is admitted, the angle valve is closed by the pressure spring. The visual position indicator is no longer visible and the electrical position indicator "valve closed" is activated.

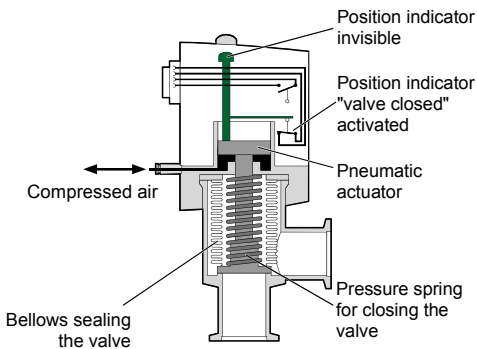

2 Safety

2.1 Symbols Used



DANGER

Information on preventing any kind of physical injury.



WARNING

Information on preventing extensive equipment and environmental damage.



Caution

Information on correct handling or use. Disregard can lead to malfunctions or minor equipment damage.

2.2 Personnel Qualifications



Skilled personnel

All work described in this document may only be carried out by persons who have suitable technical training and the necessary experience or who have been instructed by the end-user of the product.



2.3 General Safety Instructions

- Adhere to the applicable regulations and take the necessary precautions for the process media used.
Consider possible reactions between the materials (→  18) and the process media.
- Adhere to the applicable regulations and take the necessary precautions for all work you are going to do and consider the safety instructions in this document.
- Before beginning to work, find out whether any vacuum components are contaminated. Adhere to the relevant regulations and take the necessary precautions when handling contaminated parts.

Communicate the safety instructions to all other users.

2.4 Liability and Warranty

Pfeiffer Vacuum assumes no liability and the warranty becomes null and void if the end-user or third parties

- disregard the information in this document
- use the product in a non-conforming manner
- make any kind of interventions (modifications, alterations etc.) on the product
- use the product with accessories not listed in the product documentation.

The end-user assumes the responsibility in conjunction with the process media used.

Failures due to contamination or wear and tear, as well as expendable parts (e.g. seals), are not covered by the warranty.



3 Technical Data

Pilot valve			
Nominal voltage	→ product nameplate		
Power			
DC voltage	2.5 W		
AC voltage	4.8 / 3.6 VA		
Duty cycle	100%		
Nominal diameter	1.2 mm		
Electrical position indicator			
Connection	soldered joints		
Rating	250 VAC / 25 VA / 0.1 A 50 VDC / 12.5 W / 0.25 A		
Vacuum connection	DN 16 ISO-KF	DN 25 ISO-KF	DN 40 ISO-KF
Actuation	opening: pneumatic closing: by pressure spring		
Compressed air supply			
Tube connection	ø4 mm, ø6 mm or ø1/4"		
Pressure range	4 ... 8 bar (overpressure)		
Purity classes	2 4 1 (ISO 8573-1)		
Piston displacement	4 cm ³	11 cm ³	35 cm ³
Stroke of valve plate	6 mm	8 mm	13 mm
Conductance ¹⁾			
Angle valve	5 l/s	14 l/s	45 l/s
Inline valve	2.5 l/s	7 l/s	20 l/s
Switching frequency ²⁾	100 / min	100 / min	75 / min
Opening time ³⁾	100 ms	120 ms	260 ms
Closing time ⁴⁾	100 ms	160 ms	540 ms

¹⁾ For air with molecular flow.

²⁾ With pressure difference $\Delta p=0$ and compressed air = 5 bar (overpressure).

³⁾ With compressed air = 4 bar (overpressure) and vacuum in the valve.



Cycle life ⁵⁾	10 million
Tightness	1×10 ⁻⁹ mbar l/s
Pressure max.	5 bar (absolute)
Operating pressure min.	1×10 ⁻⁸ mbar
Operating pressure max.	2 bar
Pressure difference Δp	
In closing direction	5 bar
In opening direction	2 bar
Temperature	
Ambiance	0 °C ... +50 °C
Bakeout	
Housing	
Aluminum	80 °C
Stainless steel	150 °C
Actuator	50 °C
Pilot valve	50 °C
Use	altitude up to 2500 m NN
Type of protection	IP 50
Protection class	II
Mounting orientation	any
Flow direction ⁶⁾	any

⁴⁾ With compressed = 8 bar (overpressure) and atmosphere in the valve.

⁵⁾ Cycles without expendable parts (seals) and under clean operating conditions.
If the valve is operated under harsh or dirty conditions, it should be cleaned / maintained before the specified service time to maintenance has been reached.

⁶⁾ Recommended mounting orientation: valve seat toward vacuum chamber.



Materials			
Housing			
Aluminum			EN AW-6060
Stainless steel			1.4301
Bellows / valve plate			1.4404 / 1.4435
Pressure spring			spring steel
Seals			FPM
Cover			ABS
Visual position indicator			POM
Cylinder unit			EN AW-6060
Protective lid			PE
Packing material			carton box, PE
Weight			
Angle valve			
Aluminum	0.49 kg	0.68 kg	1.21 kg
Stainless steel	0.52 kg	0.75 kg	1.33 kg
Inline valve			
Stainless steel	0.89 kg	1.35 kg	2.2 kg



Dimensions [mm]

- Angle valve

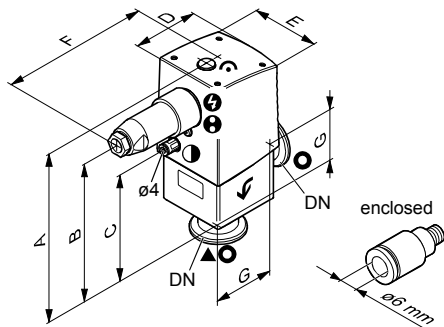

- | | | | |
|--|-------------------------------|--|-----------------|
| | Visual position indicator | | Valve seat site |
| | Compressed air connection | | Flow direction |
| | Position indicator connection | | Protective lid |
| | Power connection | | |

Aluminum housing

DN	A	B	C	D	E	F	G
DN 16 ISO-KF	142	112.9	75.1	55	51.4	93.2	40
DN 25 ISO-KF	146.9	117.8	79	64.3	60.1	97.8	50
DN 40 ISO-KF	188.8	159.7	114.9	81.3	75.7	105.3	65





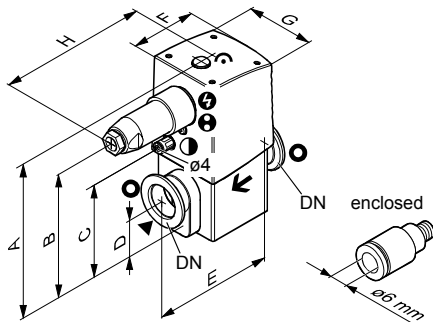

Stainless steel housing

DN	A	B	C	D	E	F	G
DN 16 ISO-KF	144.5	115.4	77.6	55	51.4	93.2	40
DN 25 ISO-KF	150.3	121.2	82.5	64.3	60.1	97.8	50
DN 40 ISO-KF	191.8	162.7	117.9	81.3	75.7	105.3	65



• Inline valve



- | | | | |
|---|-------------------------------|---|-----------------|
|  | Visual position indicator |  | Valve seat site |
|  | Compressed air connection |  | Flow direction |
|  | Position indicator connection |  | Protective lid |
|  | Power connection | | |

DN	A	B	C	D	E	F	G	H
DN 16 ISO-KF	126.1	97	59.2	20	80	55	51.4	93.2
DN 25 ISO-KF	133.6	104.5	65.7	31.8	100	64.3	60.1	97.8
DN 40 ISO-KF	169.1	140	95.2	40.8	130	81.3	75.7	105.3



4 Installation

4.1 Vacuum Connection

 **DANGER**



DANGER: overpressure in the vacuum system >1 bar

Injury caused by released parts and harm caused by escaping process gases can result if clamps are opened while the vacuum system is pressurized.

Do not open any clamps while the vacuum system is pressurized. Use the type clamps which are suited to overpressure.

 **DANGER**



DANGER: overpressure in the vacuum system >2.5 bar

KF flange connections with elastomer seals (e.g. O-rings) cannot withstand such pressures. Process media can thus leak and possibly damage your health.

Use O-rings provided with an outer centering ring.

 **Caution**



Caution: vacuum component

Dirt and damages impair the function of the vacuum component.

When handling vacuum components, take appropriate measures to ensure cleanliness and prevent damages.





Caution



Caution: dirt sensitive area

Touching the product or parts thereof with bare hands increases the desorption rate.

Always wear clean, lint-free gloves and use clean tools when working in this area.

Remove the protective lids and connect the product to the vacuum system.

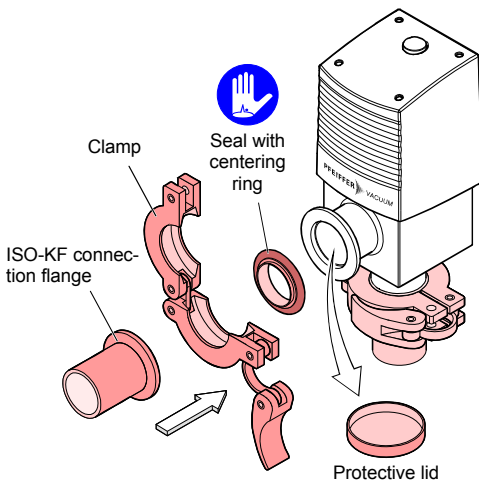

Keep the protective lids.



4.2 Compressed Air Connection

 **DANGER**



DANGER: compressed air

Unprofessionally handling compressed air can cause physical injury.

Adhere to the relevant regulations and take the necessary precautions when handling compressed air.

Instant push-in fitting

The standard product is equipped with an instant push-in fitting for a plastic tube $\varnothing 4$ mm.

If you are using a $\varnothing 6$ mm or a $\varnothing 1/4$ " plastic tube, exchange the instant push-in fitting.

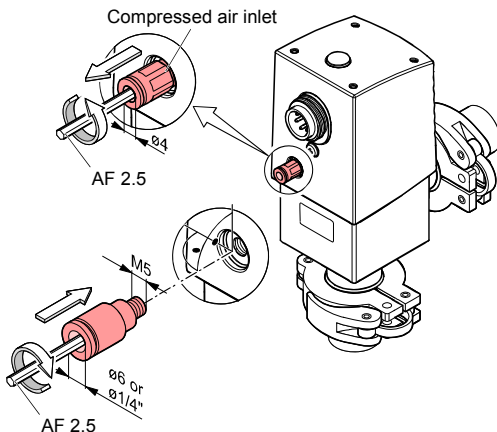

Plastic tube



DANGER



DANGER: moving parts

When the product is connected to the supply media, parts can start moving. Moving parts can catch parts of the body and cause injuries.

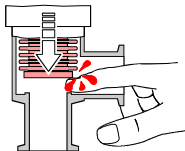

The connection to the compressed air supply may only be established if

- the compressed air line is not pressurized
- the product is installed in a vacuum system or
- the moving parts are protected to avoid accidental contact.



Specifications for the plastic tube:

- bursting pressure ≥ 10 bar overpressure
- material: PA soft or PU





To ensure leak tightness:

- cut the plastic tube orthogonally
- make sure the outside of the plastic tube is not damaged

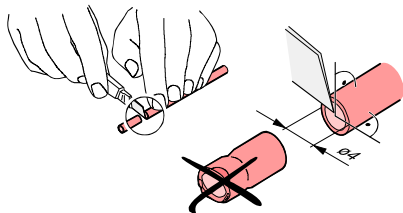

Push the plastic tubes into the instant push-in fittings until the stop position is reached and check for correct mounting by slightly pulling.

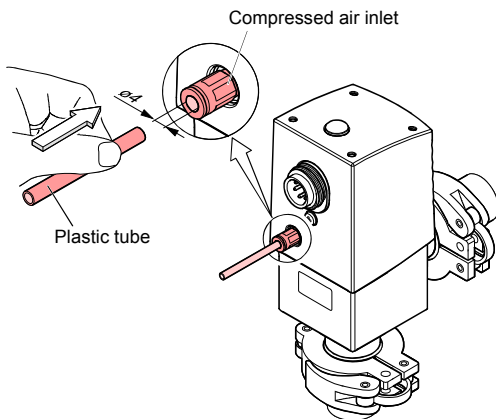

Compressed air control system

The compressed air control system has to be supplied by the end-user.



The compressed air must meet the following specifications:

- purity classes 2 4 1 (ISO 8573-1)
- 4 ... 8 bar overpressure

To reach the opening and closing times indicated in the "Technical Data", a pilot valve with a nominal diameter of >2 mm is required.

4.3 Power Connection



Caution



Caution: supply voltage

Incorrect voltages can destroy the product.

The supply voltage ratings must correspond to the nominal voltage of the product (→ product nameplate). If they do not correspond, exchange the product.



 **DANGER**

DANGER: moving parts

When the product is connected to the supply media, parts can start moving. Moving parts can catch parts of the body and cause injuries.

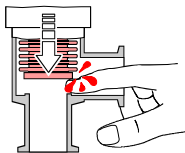

The connection to the power supply may only be established if

- the power supply is de-energized
- the product is installed in a vacuum system or
- the moving parts are protected to avoid accidental contact.



The cable must meet the following specifications:

- flexible
- conductor cross-section $\leq 0.75 \text{ mm}^2$
- cable cross-section $\leq 10 \text{ mm}$
- 6-pole (with pilot valve)
4-pole (without pilot valve).



1 Prepare the connector.

Valve with pilot valve



The polarity of the pilot valve (solenoid coil) need not be taken into consideration.

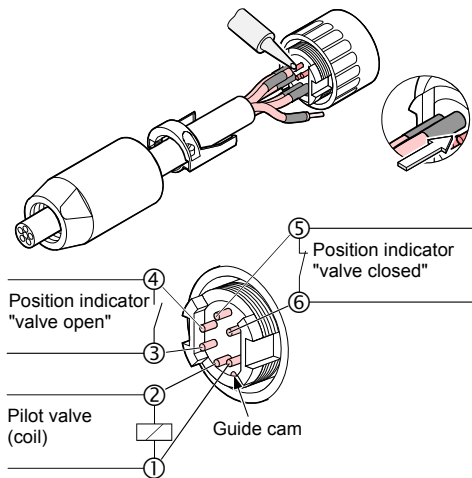

Valve without pilot valve

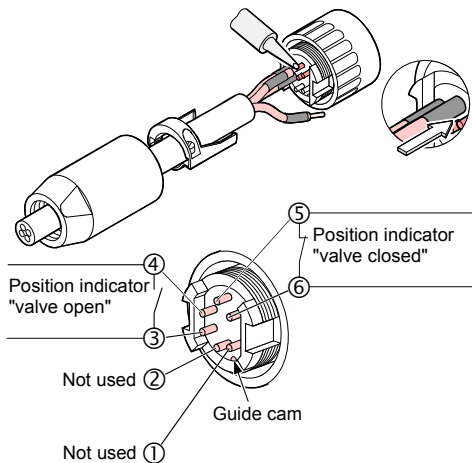

- 2 Plug in the connector and secure it with the union nut.

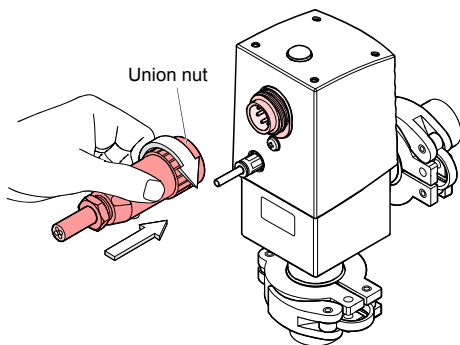

5 Operation

The product is ready for operation as soon as it has been installed.

5.1 Valve with Pilot Valve, Normally Closed

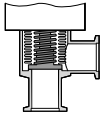
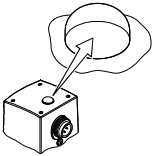
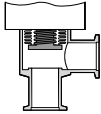
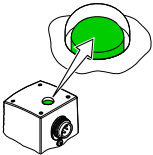
Valve position	Compressed air	Pilot valve	Position indicator
closed 	available	deactivated	
	not available	activated	
	not available	deactivated	
open 	available	activated	

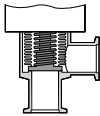
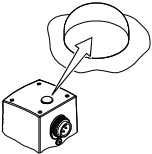
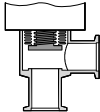
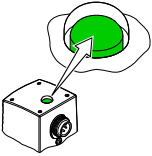

5.2 Valve with Pilot Valve, Normally Open

Valve position	Compressed air	Pilot valve	Position indicator
closed 	available	activated	
	not available	activated	
	not available	deactivated	
open 	available	deactivated	

5.3 Valve without Pilot Valve

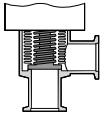
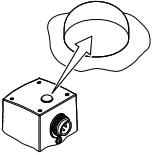
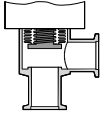
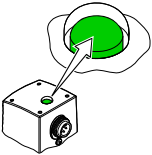
Valve position	Compressed air	Position indicator
closed 	not available	
open 	available	





6 Deinstallation

Precondition

- Vacuum system vented.

6.1 Power Connection

**DANGER**



DANGER: moving parts

When the product is disconnected from the supply media, parts can start moving. Moving parts can catch parts of the body and cause injuries.

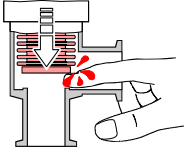

The product may only be disconnected from the power supply if

- the product is installed in a vacuum system or
- the moving parts are protected to avoid accidental contact.



Before connecting or disconnecting the product, turn off the control system.



Loosen the connector and unplug it.

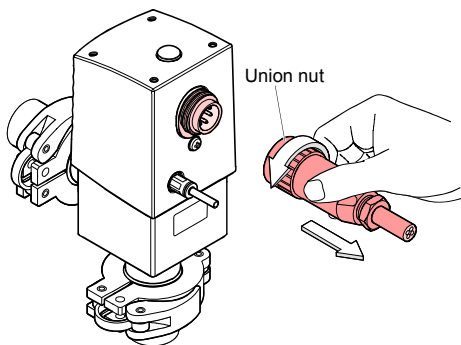

6.2 Compressed Air Connection

**DANGER**



DANGER: moving parts

When the product is disconnected from the supply media, parts can start moving. Moving parts can catch parts of the body and cause injuries.

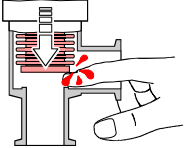

The product may only be disconnected from the compressed air if

- the product is installed in a vacuum system or
- the moving parts are protected to avoid accidental contact.

**DANGER**



DANGER: compressed air

Physical injury can result if a pressurized compressed air line is disconnected.

Before doing any work, turn off the compressed air supply and relieve the compressed air lines.



Pull out the tube while depressing the thrust ring.

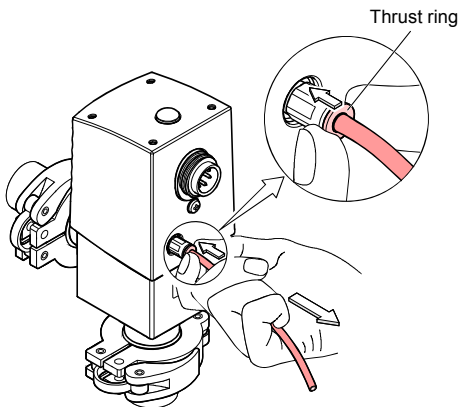

6.3 Vacuum Connections



DANGER



DANGER: contaminated parts

Contaminated parts can be detrimental to health and environment.

Before beginning to work, find out whether any parts are contaminated. Adhere to the relevant regulations and take the necessary precautions when handling contaminated parts.



Caution



Caution: vacuum component

Dirt and damages impair the function of the vacuum component.

When handling vacuum components, take appropriate measures to ensure cleanliness and prevent damages.



Caution



Caution: dirt sensitive area

Touching the product or parts thereof with bare hands increases the desorption rate.

Always wear clean, lint-free gloves and use clean tools when working in this area.



Remove the valve from the vacuum system and install the protective lids.

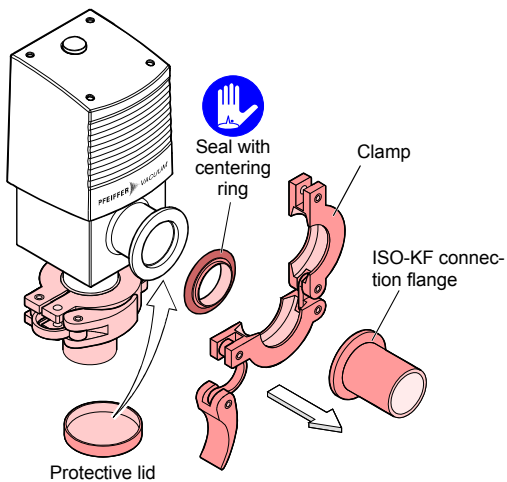

7 Maintenance / Repair



Failures due to contamination or wear and tear, as well as expendable parts (e.g. seals), are not covered by the warranty.

DANGER



DANGER: contaminated parts

Contaminated parts can be detrimental to health and environment.

Before beginning to work, find out whether any parts are contaminated. Adhere to the relevant regulations and take the necessary precautions when handling contaminated parts.



Caution



Caution: vacuum component

Dirt and damages impair the function of the vacuum component.

When handling vacuum components, take appropriate measures to ensure cleanliness and prevent damages.



Caution



Caution: dirt sensitive area

Touching the product or parts thereof with bare hands increases the desorption rate.

Always wear clean, lint-free gloves and use clean tools when working in this area.



7.1 Cleaning / Replacing Bellows and Seals

Precondition

- Valve deinstalled (Deinstallation → 33)

- 1 Unscrew the hexagon socket head screws and remove the actuator from the housing.



The actuator can be rotated in steps of 90 °.

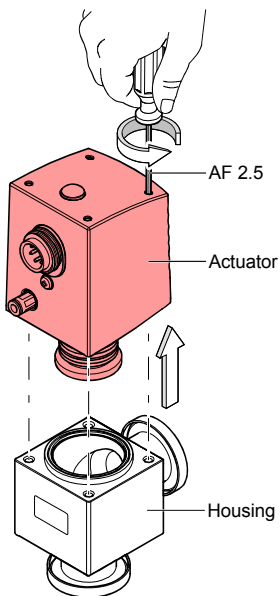

- 2** Unscrew the bellows (Spare Parts →  45).

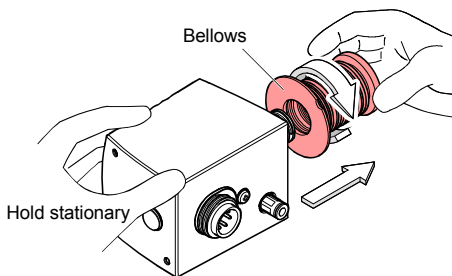

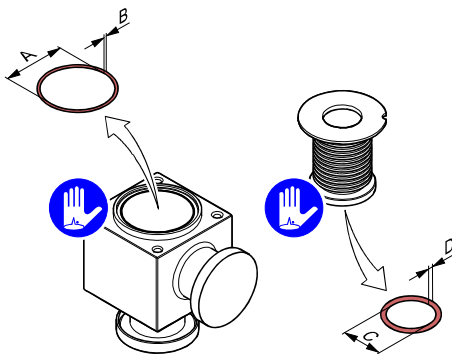

- 3** Remove the seals (Spare Parts →  45).



O-ring, FPM	$\varnothing A \times B$	$\varnothing C \times D$
DN 16 ISO-KF	$\varnothing 28.3 \times 1.78$	$\varnothing 17.04 \times 3.53$
DN 25 ISO-KF	$\varnothing 37.82 \times 1.78$	$\varnothing 24.99 \times 3.53$
DN 40 ISO-KF	$\varnothing 56.87 \times 1.78$	$\varnothing 40.87 \times 3.53$



- 4 Remove the protective lids and clean the parts.

	 DANGER
	<p>DANGER: cleaning agents</p> <p>Cleaning agents can be detrimental to health and environment.</p> <p>Adhere to the relevant regulations and take the necessary precautions when handling and disposing of cleaning agents. Consider possible reactions with the product materials (→  18).</p>

Procedure

- Carefully clean the parts with a grease solving, non-scouring cleaner.
- After cleaning the parts should preferably be rinsed with alcohol and subsequently heated to $\approx 50^{\circ}\text{C}$ in an oven or with an industrial blower.
- Carefully clean the sealing surfaces with a lint-free cloth soaked with alcohol. Allow them to dry.

- 5 Proceed in reverse order to reassemble the product.



Be careful to insert the O-rings level into the grooves without twisting them.

After reassembly, a few switching cycles should be performed in order for the O-rings to perfectly adapt to the sealing surfaces. Take the necessary precautions for this procedure.



7.2 Replacing the Cover

Precondition

- Disconnected from the power supply (→ 33)
- Disconnected from the compressed air supply (→ 35)

- 1 Unscrew the instant push-in fitting and the screw and remove the cover.

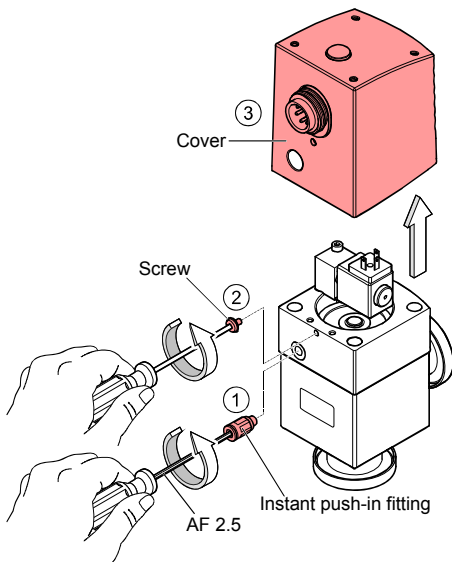

- 2** Place the cover and screw in the screw and instant push-in fitting.

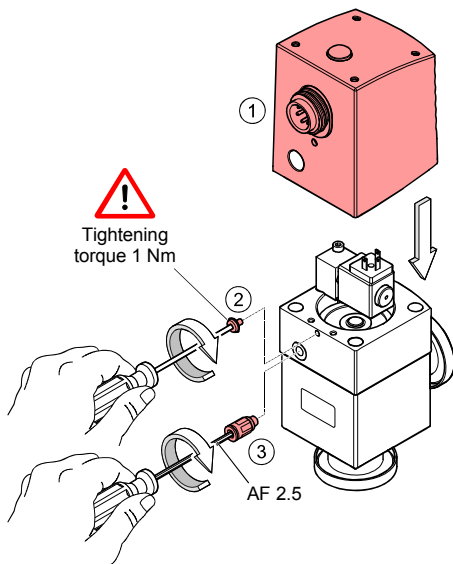

8 Spare Parts

Seal kit

		Ordering No.
	DN 16 ISO-KF, comprising 1 O-ring, FPM75, $\varnothing 17.04 \times 3.53$ 1 O-ring, FPM75, $\varnothing 28.3 \times 1.78$	PT 130 300-T
	DN 25 ISO-KF, comprising 1 O-ring, FPM75, $\varnothing 24.99 \times 3.53$ 1 O-ring, FPM75, $\varnothing 37.82 \times 1.78$	PT 130 301-T
	DN 40 ISO-KF, comprising 1 O-ring, FPM75, $\varnothing 40.87 \times 3.53$ 1 O-ring, FPM75, $\varnothing 56.87 \times 1.78$	PT 130 302-T

Bellows cpl.

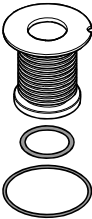
		Ordering No.
	DN 16 ISO-KF, comprising 1 bellows 1 O-ring, FPM75, $\varnothing 17.04 \times 3.53$ 1 O-ring, FPM75, $\varnothing 28.3 \times 1.78$	PT 130 303-T
	DN 25 ISO-KF, comprising 1 bellows 1 O-ring, FPM75, $\varnothing 24.99 \times 3.53$ 1 O-ring, FPM75, $\varnothing 37.82 \times 1.78$	PT 130 304-T
	DN 40 ISO-KF, comprising 1 bellows 1 O-ring, FPM75, $\varnothing 40.87 \times 3.53$ 1 O-ring, FPM75, $\varnothing 56.87 \times 1.78$	PT 130 305-T

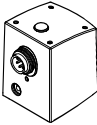

Cover cpl.

		Ordering number
	DN 16 ISO-KF, comprising 1 cover with receptacles 1 visual position indicator 1 electrical position indicator	PT 130 306-T
	DN 25 ISO-KF, comprising 1 cover with receptacles 1 visual position indicator 1 electrical position indicator	PT 130 307-T
	DN 40 ISO-KF, comprising 1 cover with receptacles 1 visual position indicator 1 electrical position indicator	PT 130 308-T

9 Accessories

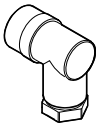
		Ordering number
	Female cable connector right angled, 6+PE	PT 130 309-T



10 Returning the Product



WARNING



WARNING: forwarding contaminated products
Contaminated products (e.g. radioactive, toxic, caustic or microbiological hazard) can be detrimental to health and environment.

Products returned to Pfeiffer Vacuum should preferably be free of harmful substances. Adhere to the forwarding regulations of all involved countries and forwarding companies and enclose a duly completed declaration of contamination ⁷⁾.

Products that are not clearly declared as "free of harmful substances" are decontaminated at the expense of the customer. Products not accompanied by a duly completed declaration of contamination are returned to the sender at his own expense.

⁷⁾ Form under www.pfeiffer-vacuum.net



11 Disposal



DANGER



DANGER: contaminated parts

Contaminated parts can be detrimental to health and environment.

Before beginning to work, find out whether any parts are contaminated. Adhere to the relevant regulations and take the necessary precautions when handling contaminated parts.



WARNING



WARNING: substances detrimental to the environment

Products or parts thereof (mechanical and electric components, operating fluids etc.) can be detrimental to the environment.

Dispose of such substances in accordance with the relevant local regulations.

Separating the components

After disassembling the product, separate its components according to the following criteria:

- Contaminated components
Contaminated components (radioactive, toxic, caustic or biological hazard etc.) must be decontaminated in accordance with the relevant national regulations, separated according to their materials, and disposed of.
- Other components
Such components must be separated according to their materials and recycled.



**Leading. Dependable.
Customer Friendly.**

Pfeiffer Vacuum stands for innovative and custom vacuum solutions worldwide. For German engineering art, competent advice and reliable services.

Ever since the invention of the turbopump, we've been setting standards in our industry. And this claim to leadership will continue to drive us in the future.

**You are looking for a
perfect vacuum solution?
Please contact us:**

Germany
Pfeiffer Vacuum GmbH
Headquarters
Tel.: +49 (0) 6441 802-0
info@pfeiffer-vacuum.de

Benelux
Pfeiffer Vacuum GmbH
Sales & Service Benelux
Tel.: +800-pfeiffer
benelux@pfeiffer-vacuum.de

China
Pfeiffer Vacuum
(Shanghai) Co., Ltd.
Tel.: +86 21 3393 3940
info@pfeiffer-vacuum.cn

France
Pfeiffer Vacuum France SAS
Tel.: +33 169 30 92 82
info@pfeiffer-vacuum.fr

Great Britain
Pfeiffer Vacuum Ltd.
Tel.: +44 1908 500600
sales@pfeiffer-vacuum.co.uk

India
Pfeiffer Vacuum India Ltd.
Tel.: +91 40 2775 0014
pfeiffer@vsnl.net

Italy
Pfeiffer Vacuum Italia S.p.A.
Tel.: +39 02 93 99 05 1
contact@pfeiffer-vacuum.it

Korea
Pfeiffer Vacuum Korea Ltd.
Tel.: +82 31 266 0741
sales@pfeiffer-vacuum.co.kr

Austria
Pfeiffer Vacuum Austria GmbH
Tel.: +43 1 894 17 04
office@pfeiffer-vacuum.at

Sweden
Pfeiffer Vacuum Scandinavia AB
Tel.: +46 8 590 748 10
sales@pfeiffer-vacuum.se

Switzerland
Pfeiffer Vacuum (Schweiz) AG
Tel.: +41 44 444 22 55
info@pfeiffer-vacuum.ch

United States
Pfeiffer Vacuum Inc.
Tel.: +1 603 578 6500
contact@pfeiffer-vacuum.com

